

# Installation Instructions for the D-IntuiSwitch™ Controller

## What's in the Package

The following items are included in the package with a D-IntuiSwitch™ controller:

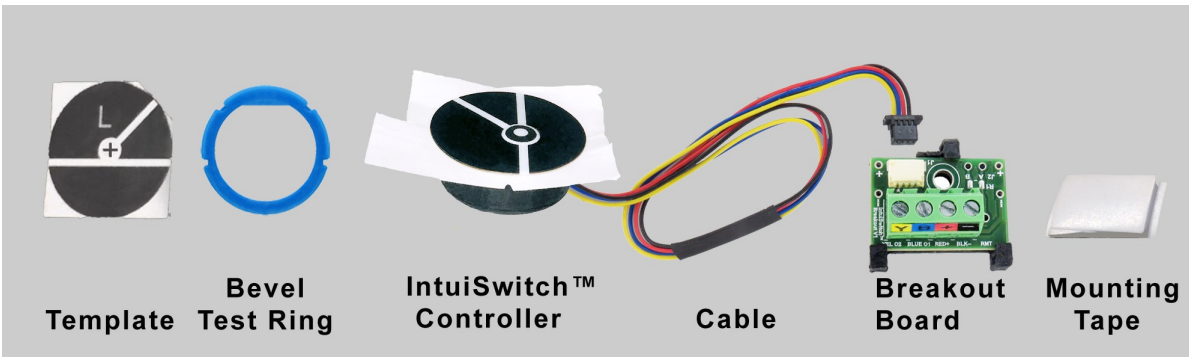

## Mounting the controller

The D-IntuiSwitch™ controller's cylindrical housing is designed to fit a 1" diameter hole.

The supplied template may be used to align the mounting hole with track images. When the tracks on the template are aligned with the tracks on the mounting surface, the cross hair of the drill template indicates the center of hole to be drilled. Drilling with a Forstner 1" bit is recommended. The cylindrical body should fit snugly.

A flared lip just below the controller's facing (top cover) keeps the housing from getting pushed through the mounting hole. The facing overlaps the cylindrical body and has an adhesive coating on its underside to secure the controller on the mounting surface. To allow the controller's adhesive coated outer edge to adhere to the mounting surface, the front edge of the hole needs to be beveled to accommodate the lip. The beveling can be achieved by using a file, sand paper, emery cloth, scraper, Exacto knife, or our IntuiSwitch beveling tool (available separately).

The included non-adhesive blue test ring has a lip with the same dimensions as the controller. It can be used to check that you've sufficiently beveled the mounting hole before installing the controller. The beveling is sufficient when the blue test ring can be inserted deep enough in the hole that its top is flush with the top of the mounting surface. Then remove the blue test ring before installing the control.

A removable release paper liner protects the adhesive on the underside of the facing during shipping and until you are ready to finalize installation of the controller. When the mounting hole is properly prepared, the controller should go in the hole far enough to hold the release paper tightly against the mounting surface. Align the controller, remove the protective liner, and burnish the controller's to the mounting surface. The adhesive edge should contact the mounting surface to prevent the controller from rotating.

## Wiring the controller

Choose a location for the wiring breakout board, which provides an easy interface between the 8" cable attached to the IntuiSwitch controller and your layout wiring.

You can secure the breakout board to benchwork with a #4 screw or with the supplied white mounting tape.

The cable from the IntuiSwitch™ controller plugs into the white connector on the breakout board. Orient the cable so its black wire is nearest the large hole in the breakout board. Hold the cable parallel to the breakout board when inserting it into or removing it from the white connector.

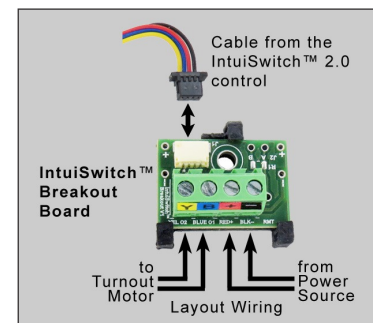

The controller can be powered by 12-24 Vdc (15 Vdc is recommended), 10-16 Vac, or DCC track power. Because each turnout's stall motor draws power (18 mA with the controller), connecting many controllers to track power reduces the power available to the trains. A separate dedicated source is recommended. Connect the power to the black (-) and the red (+) screw terminals on the breakout board, observing polarity if using a DC power source.

Connect the turnout's motor to the blue and yellow screw terminals on the breakout board. Swap the two leads if needed to match the turnout's status to that shown on the controller.